



# MAUKA hexapod

High precision in a small diameter



## KEY FEATURES

- Small diameter of 107 mm
- Payload capacity up to 5 kg
- Angular travel range  $\pm 8^\circ$
- Absolute encoders



## APPLICATIONS

- Optics
- Synchrotrons
- Space
- Astronomy

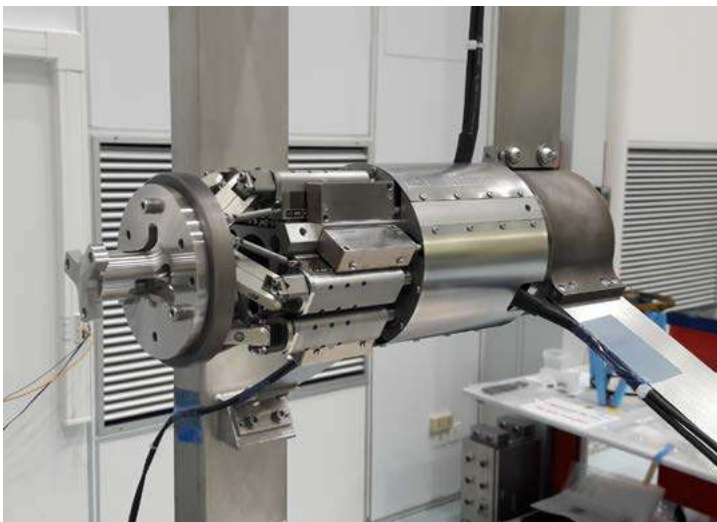

MAUKA hexapod with the interface to the glue box that will fix a mirror on a space telescope



MAUKA hexapod has a very small diameter of 107 mm.

MAUKA	
<b>Motion and positioning</b>	
Travel range Tx, Ty (mm)	± 5
Travel range Tz (mm)	± 10
Travel range Rx, Ry (deg)	± 8
Travel range Rz (deg)	± 8
Resolution Tx, Ty, Tz (µm)	0.5
Resolution Rx, Ry, Rz (µrad)	5
Repeatability Tx, Ty, Tz (µm)	± 0.5
Repeatability Rx, Ry, Rz (µrad)	± 5
Speed Tx, Ty (mm/s)	1.6
Speed Tz (mm/s)	1
Speed (deg/s)	2
<b>Mechanical properties</b>	
Stiffness X, Y (N/µm)	1.2
Stiffness Z (N/µm)	8
Payload capacity (kg) (vertical orientation / horizontal orientation)	5 / 2.5
Motor type	DC motor, gearhead
Encoder type	Absolute linear encoder
<b>Miscellaneous</b>	
Operating temperature range (°C)	0 to + 50
Materials	Aluminum, steel, stainless steel
Mobile platform size (mm)	Ø 90
Mobile platform central aperture (mm)	Ø 38
Fixed platform size (mm)	Ø 100
Fixed platform central aperture (mm)	Ø 30
Height in middle position (mm)	198
Footprint (mm)	Ø 107
Mass (kg)	3
Cable length (m)	3
Options	Clean room compatibility Vacuum compatibility Customized platform design Outdoor use Scalable size
<b>Controller</b>	
Controller type	ALPHA+
Interface	Ethernet
Power supply	110-240 VAC / 50-60 Hz

Datasheet subject to change without notice. All data are superseded by any new release. R200525

The performances are specified for single axis motions, with all other axes at midrange and for a rotation center in the middle of the mobile platform.

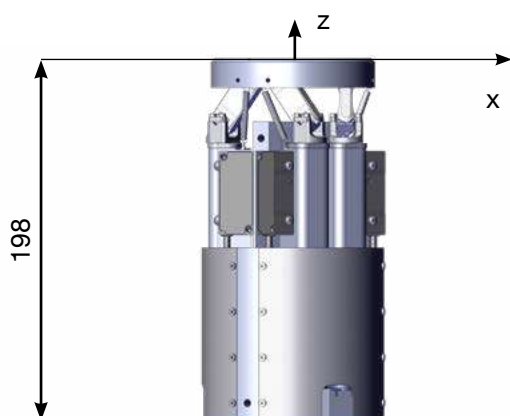

Hexapod in middle position

